

Directions for calibration of vacuum switches

Type 901.20/21



This pressure switch may only be mounted, connected and started up by trained technicians. You must ensure, that the electrical connections are not live and the pressure switch is not pressurized or under high temperature before starting any work. Otherwise, this might endanger life due to electrical shock, leaking medium or high temperatures. The valid safety regulations, intended use and technical data must be observed. In accordance with these regulations, the system voltage must be switched off and secured >from being unintentionally switched on again. Damaged products may not be used.

The pressure switches are set to a defined level by the manufacturer according to the stamped numeral (= trip pressure) by means of tuned sets of springs. In case of readjustment by the user, all warranty claims become void. The following directions should only serve to establish the correct pressure setting.

Range of calibration

The pressure switch can be adjusted to trip pressure of between -5 and -800 mbar (dependent on the built-in set of springs).

Switching differential depends on the built-in set of springs and must be agreed between customer and manufacturer.

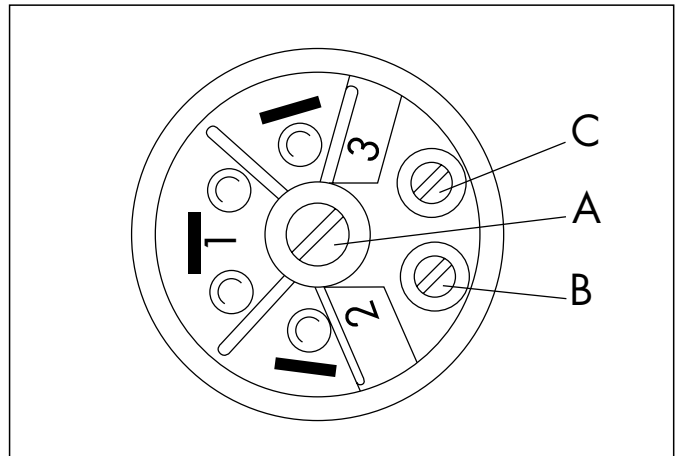

Arrangement of contacts

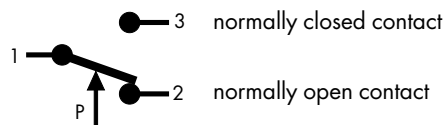

Each pressure switch has 3 adjusting screws (A, B, C).

Screw A is to be used exclusively if adjustment position has to be changed.

Screw B permits small changes of the reset pressure (2 → 3).

Screw C permits small changes of the trip pressure (3 → 2).

Please note when turning screw B and C that contact clearance may not be in zero-position, as otherwise the switch is short-circuiting.

Calibration

Screw:	A		B		C	
Result	changes the level, i.e. both the trip and the reset pressure at the same time and in same direction		changes reset pressure		changes trip pressure	
turn to	right	left	right	left	right	left
result at	up	down	down	up	no change	
reset pressure	up	down	no change		down	up
trip pressure	remains almost constant		decreases	increases	increases	decreases
switching differential	linear dependence according to built-in set of springs		no linear dependence			

