

Beck.

The differential pressure transmitter 985A for air

with automated offset compensation



Differential pressure transmitter 985A

with automated offset compensation



General description

The differential pressure transmitters of the 985A series are used to measure differential pressure, overpressure and vacuum.

They provide 2 pressure ranges and 2 output signals, which are selectable using a jumper.

Applications

Monitoring of gaseous, non-aggressive media. Possible usage areas are:

- Building automation, air conditioning systems and clean room monitoring
- Valve and flap control
- Filter, ventilator and blower monitoring
- Control of air flows

Configurable pressure range

For optimum adaptation to the pressure application, the transmitter can be switched between two pressure ranges. The factory setting is the sensitive range 1, which is selected by fitting a jumper. Removing the jumper activates the non-sensitive range 2.

Configurable response time

The response time of the output signal can be configured using a jumper. If the jumper is in place the response time is slow (factory setting), which is useful for suppressing brief pressure peaks. If the application requires a fast response time the jumper must be removed.

Volume flow measurement

The shape of the output signal can be switched from linear to square root using a jumper in order to measure the volume flow via a differential pressure.

Output signal selection

The output signal of the 3-wire version is configurable. The factory setting is for a 0 ... 10 Volt output signal, but this can be changed to 4 ... 20 mA by removing the jumper.

Automated offset compensation

In regular intervals any drift of the zero-point is automatically compensated. No re-calibration is normally needed which reduces monitoring and maintenance efforts.

Measuring method

Piezoresistive pressure transducer

Mounting position

Can be mounted in any position. The self-compensating piezoresistive pressure transducer eliminates any possible mounting error.

Technical data

Supply voltage	22 ... 24 ... 30 VAC/VDC
• 3-wire version	
Output signal	0 ... 10 V and 4 ... 20 mA
• 3-wire version	
Load for 4 ... 20 mA output	20 ... 500 Ω
max. current draw	without display < 60 mA with display < 150 mA
Pressure medium	Air and non-aggressive gases
Linearity and hysteresis error	$\leq \pm 1\%$ of FS
Working temperature	0 ... 50 °C
Storage temperature	-10 ... 70 °C
Typical long-term stability	$\leq \pm 0.5\%$ to $\pm 2.5\%$ of FS/year, depending on pressure range
Repetition accuracy	$\leq \pm 0.2\%$ of FS
Position dependence	$\leq \pm 0.02\%$ of FS/g
Humidity	0 ... 95 % rel, non-condensing
Response time, selectable	1 s or 100 ms
Process connection	4 and 6 mm hose connection brass nickel-plated
Electrical connection	Screw terminal block for wires and strands up to 1.5 mm ²
Mounting	Screw mounting with serrated screws
Display, optional	Red LED display, 4 digits
Housing material	ABS
Housing dimensions	approx. 81 x 83 x 60 mm
Weight	approx. 190 g
Protection class	IP 65
Cable conduit for protection cap	M12x1.5 threaded connection, made of polyamide
CE Conformity	2004/108/EC (EMC) 2002/95/EC (RoHS)

Pressure ranges

Model	Range 1	Range 2	Overload capacity	Bursting pressure	Temperature error of FS
985A.303	0 ... 25 Pa	0 ... 50 Pa	20 kPa	40 kPa	≤ ± 5 % of FS
985A.313	0 ... 50 Pa	0 ... 100 Pa	20 kPa	40 kPa	≤ ± 5 % of FS
985A.323	0 ... 100 Pa	0 ... 250 Pa	20 kPa	40 kPa	≤ ± 2.5 % of FS
985A.333	0 ... 250 Pa	0 ... 500 Pa	20 kPa	40 kPa	≤ ± 2.5 % of FS
985A.343	0 ... 500 Pa	0 ... 1,000 Pa	20 kPa	40 kPa	≤ ± 1.5 % of FS
985A.353	0 ... 1 kPa	0 ... 2.5 kPa	40 kPa	70 kPa	≤ ± 1 % of FS
985A.373	0 ... 5 kPa	0 ... 10 kPa	60 kPa	120 kPa	≤ ± 1 % of FS
985A.393	0 ... 25 kPa	0 ... 50 kPa	300 kPa	500 kPa	≤ ± 1 % of FS
985A.3B3	0 ... 100 kPa	0 ... 250 kPa	1.2 MPa	2 MPa	≤ ± 1 % of FS

Order matrix

Configurable pressure ranges	0 ... 25 Pa (0.25 mbar)	0 ... 50 Pa (0.5 mbar)	985A.3	0			
	0 ... 50 Pa (0.5 mbar)	0 ... 100 Pa (1.0 mbar)		1			
	0 ... 100 Pa (1.0 mbar)	0 ... 250 Pa (2.5 mbar)		2			
	0 ... 250 Pa (2.5 mbar)	0 ... 500 Pa (5.0 mbar)		3			
	0 ... 500 Pa (5.0 mbar)	0 ... 1,000 Pa (10 mbar)		4			
	0 ... 1 kPa (10 mbar)	0 ... 2.5 kPa (25 mbar)		5			
	0 ... 5 kPa (50 mbar)	0 ... 10 kPa (100 mbar)		7			
	0 ... 25 kPa (250 mbar)	0 ... 50 kPa (500 mbar)		9			
	0 ... 100 kPa (1,000 mbar)	0 ... 250 kPa (2,500 mbar)		B			
Pressure unit	Pascal			3			
Output signal and	0 ... 10 Volt and 4 ... 20 mA, 3-wire, 24 VAC/VDC, without switching output				7		
	4 ... 20 mA and 0 ... 10 Volts, 3-wire, 24 VAC/VDC, without switching output				D		
Display	No display					0	
	With LED-Display, 3.5 digits					1	
Electrical connection via screw terminal block							4

Factory settings printed in bold type.

Accessories

Climaset® consisting of 2m PVC hose and 2 plastic pipes	Article No. 6555
Climaset® consisting of 2m Silicone hose and 2 plastic pipes	Article No. 6557
Climaset® consisting of 2m PVC hose and 2 angled metal pipes	Article No. 6550
Climaset® consisting of 2m Silicone hose and 2 angled metal pipes	Article No. 6556
Duct connecting pipe for Climaset® 6555	Article No. 6551
Angled metal pipe for Climaset® 6550	Article No. 6552
Rubber grommet for Climaset® 6550	Article No. 6553
Roll with 100 m PVC hose	Article No. 6424
Roll with 100 m Silicone hose	Article No. 6425

Differential pressure transmitter 985A

with automated offset compensation

985A

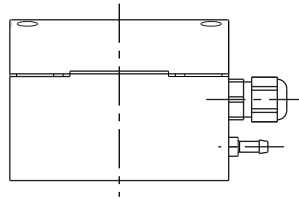
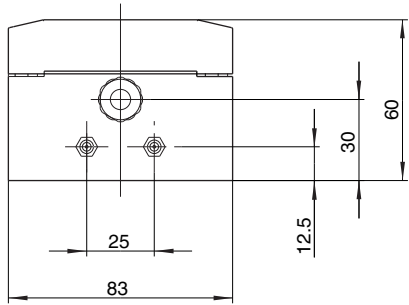

Climaset® 6550/6556

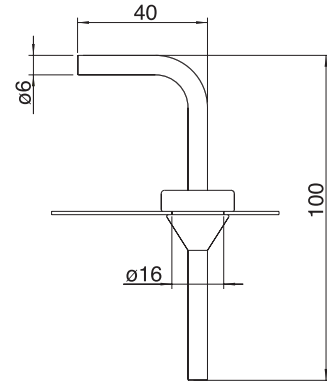

Drilling template

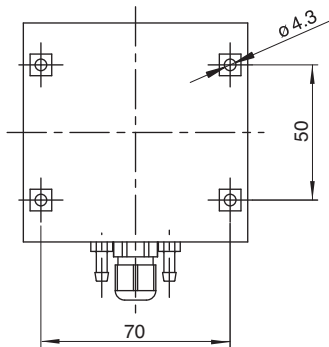
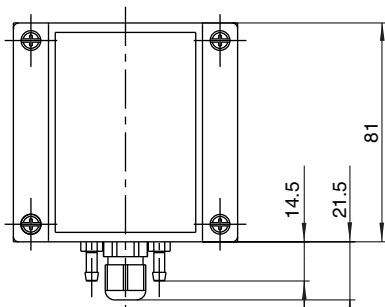

Climaset® 6555/6557

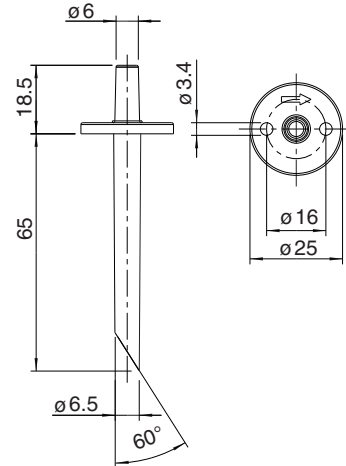

Terminal assignments 3-wire version

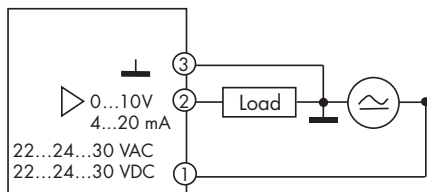

3	GO	Ground GND
2	Y	Output signal 0 ... 10 V / 4 ... 20 mA
1	G	Supply voltage 24 VAC/ VDC